NEW POLYS FOR OLD: *CONTRIBUTION OR CAVEAT?*



AMERICAN ACADEMY OF ORTHOPAEDIC SURGEONS

69th Annual Meeting
February 13 - 17, 2002
Dallas, Texas

COMMITTEE ON BIOMEDICAL ENGINEERING COMMITTEE ON HIP AND KNEE ARTHRITIS

Prepared by:

A. Seth Greenwald, D.Phil.(Oxon)
Thomas W. Bauer, M.D., Ph.D.
Michael D. Ries, M.D.



A REALITY CHECK

The enduring success of the low-friction arthroplasty first advanced by Sir John Charnley as a solution for severe hip arthritic problems may be appreciated from the fact that in 2000 more than 600,000 hip and knee arthroplasties were performed in the United States. The prevalence of aseptic loosening attributed to polyethylene debris-induced osteolysis has been in the single digits in most contemporary series, with some reports describing prostheses surviving for 20 to 30 years. (Figure 1)

Figure 1: Radiographs of a Charnley cemented hip replacement. (a) immediate post-operative; (b) 25 years post-operative.

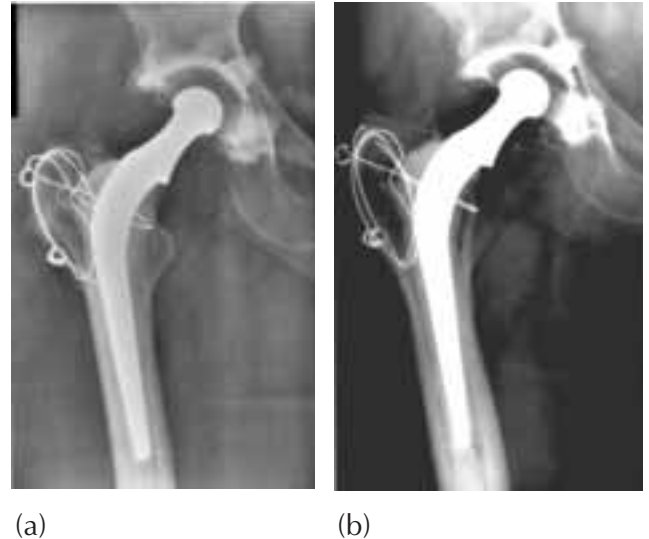

Until recently, gamma irradiation in air has been the predominant method of sterilization of ultra-high molecular weight polyethylene (UHMWPE) components and, despite current concerns, it represents the only gold standard against which contemporary material improvements will be measured over time.

STRUCTURE, STERILIZATION AND STORAGE MECHANICS

The UHMWPE used in hip and knee components results from polymerization of ethylene gas into a fine resin powder of sub-micron and micron size distribution. It is consolidated with the use of ram-extrusion or compression-molding techniques. Structurally, the polymer is made up of repeating carbon-hydrogen ($-CH_2-$) units that are arranged in ordered (crystalline) and disordered (amorphous) regions. Irradiation to sterilize components breaks the polymer chains, creating free radicals, which in an air environment combine with oxygen, facilitating ongoing oxidative degradation of the polymer. (Figure 2)

Continued exposure of the component to oxygen through prolonged shelf storage in air before clinical use results in a progressive stiffening and embrittlement of the polymer, reducing wear resistance and fatigue strength. This is thought to represent a major contributing factor influencing *in vivo* polymer failure. (Figures 3 & 4)

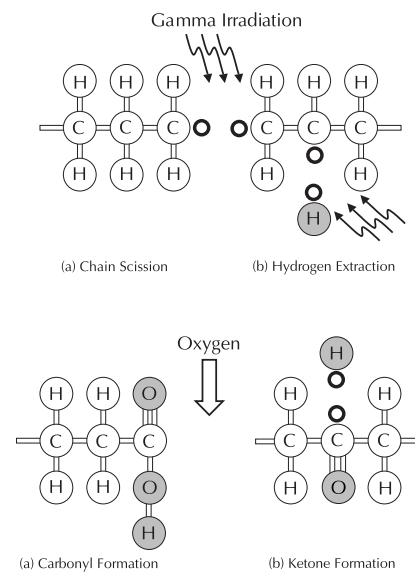

Figure 2: Depicted polymer chain breakage following irradiation in air and combination with oxygen facilitating oxidative degradation of UHMWPE.

STRUCTURE, STERILIZATION AND STORAGE MECHANICS (Cont.)

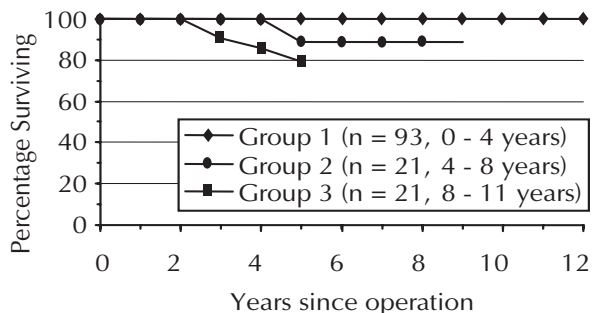

Figure 3: *The influence of shelf storage on survival of a prosthetic knee plateau following gamma irradiation in air. From Bohl, et al., Clin Orthop 367:28-38, 1999.*



Figure 4: *A Group 2 plateau implanted after 7.6 years of shelf storage and retrieved 3.8 years after implantation. Gross delamination and pitting, characteristics of fatigue failure, are observed.*

Besides reacting with oxygen, however, free radicals can also combine, creating cross-links between adjacent molecules. Bench-testing has suggested that these cross-links improve wear performance. Eliminating oxygen from the sterilization process by employing inert gas or a vacuum environment contributes to this improvement.

Alternative sterilization methods employing ethylene oxide or gas plasma without ionizing radiation avoid oxidation but do not realize potential wear performance benefits resulting from increased cross-linking. (Figure 5)

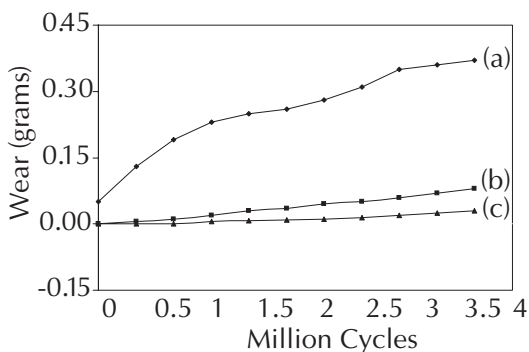

Figure 5: *Hip simulator weight-loss comparison for aged (25 days at 78°C in O₂) compression-molded cup components. (a) irradiated in air; (b) sterilized with ethylene oxide; and (c) irradiated in a vacuum environment and use of barrier packaging. From Greer, et al., Trans ORS 23:52, 1998.*

LESSONS FROM THE PAST

Previous attempts to improve the performance of UHMWPE have included carbon-fiber reinforcement (Poly-2) and, more recently, polymer reprocessing to enhance mechanical properties by hot isostatic pressing (Hylamer). The former was withdrawn from the market because of an unexpectedly high wear rate (Figure 6) while the latter, has been linked to debris-induced osteolytic response, especially when sterilized by gamma irradiation in air, in early reports. (Figure 7) Parenthetically, the Medical Devices Agency of the United Kingdom recently issued a Device Alert (MDA 2001(6), September 26, 2001) summarizing the poor clinical performance of devices utilizing Hylamer polyethylene components.



Figure 6: *A failed Poly-2 tibial insert retrieved 5 years after implantation.*



Figure 7: *A failed Hylamer acetabular cup insert retrieved 3 years after implantation.*



Figure 8: *A heat pressed tibial component retrieved 6 years after implantation.*

LESSONS FROM THE PAST (Cont.)

Heat pressing was yet another attempt to improve the finish of the articular surface, but it was associated with polyethylene fatigue and early delamination. (Figure 8)

These findings suggest that the preclinical evaluations of the previous polyethylenes did not fully predict performance *in vivo*.

CROSS-LINKED POLYETHYLENES

The new generation of cross-linked polyethylenes represents a class of emerging UHMWPE alternatives whose common denominator is an appreciation of the importance of increased cross-linking and minimization of oxidative degradation to reduce wear. Both chemical and thermal/radiation processing solutions have been advocated, with a number of the latter being recently cleared by the FDA for commercial product distribution.

Process differences include: 1) heating above or below the melt temperature of the polyethylene, 2) the radiation source, 3) dose level and 4) end-point sterilization. (Figure 9)

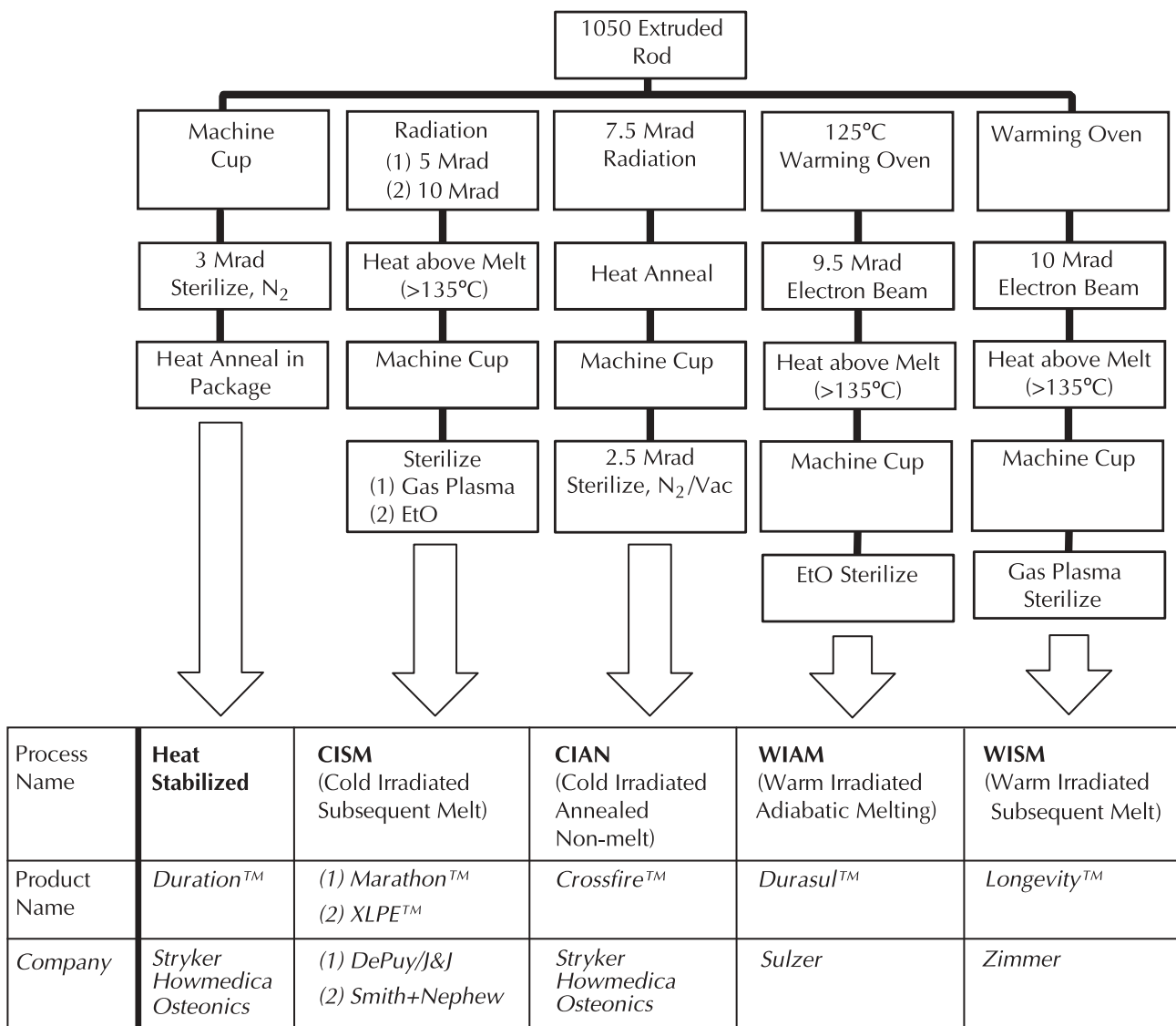

Figure 9: Current methods used to manufacture moderately to highly cross-linked polyethylene.

CROSS-LINKED POLYETHYLENES (Cont.)

In general, increasing the radiation dose dramatically reduces polymer wear in laboratory hip joint simulation. (Figure 10) Free-radical suppression through kinetic recombination at increased temperature in an oxygen-free environment or quenching through remelting represent efforts to stem the oxidation process.

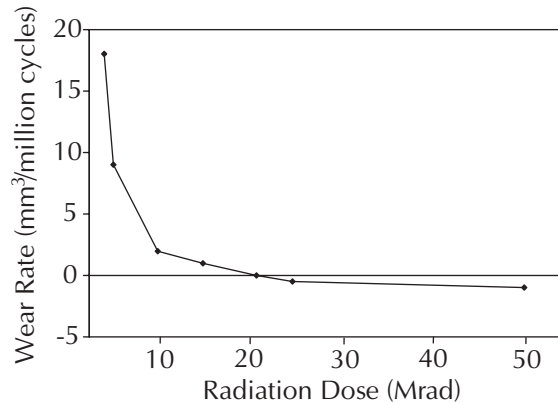
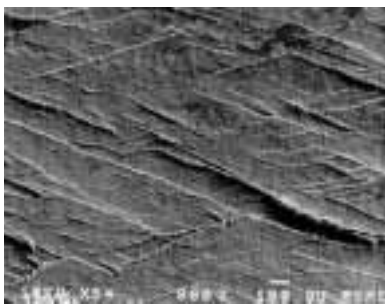

Figure 10: Mean acetabular cup wear rates versus gamma dose level. From McKellop, et al., *J Orthop Res* 17:160, 1999.

NOTES OF CAUTION

The above processes also change either the amorphous or both the amorphous and the crystalline regions of the resulting polymers, affecting mechanical properties and potentially reducing fatigue characteristics. Fatigue damage is a factor associated with high cyclic stresses in nonconforming UHMWPE knee components. It is not known how these polyethylenes will perform in knees.

There is some laboratory evidence to suggest that increased cross-linking may decrease resistance to fatigue crack propagation (Figure 11), a finding that could have implications for some modular acetabular cup designs. (Figure 12)



(a)

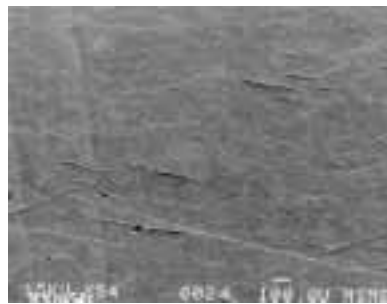

(b)

Figure 11: SEMs of polyethylene fatigue fracture specimens. (a) gas-plasma-sterilized specimen demonstrating ductile tearing associated with plastic deformation and slowing fatigue crack growth; (b) radiation cross-linked specimen demonstrating the relative absence of ductile tearing mechanisms. From Pruitt, et al., *J Biomed Mater Res*, 46:573-581, 1999.



Figure 12: Crack propagation failure of a retrieved acetabular cup associated with an inadequate locking-mechanism design.

In a recent study, 21 retrieved highly cross-linked Durasul™ liners were removed as a result of the Sulzer acetabular shell recall and analyzed using SEM. A consistent pattern of surface cracking (Figures 13-15) in the liners was seen, which has not been reported in hip simulator studies. The findings raise concerns about the capability of hip simulator studies to predict *in vivo* performance of highly cross-linked polyethylene. Reduction in the mechanical properties may contribute to the development of cracks at the articulating surface of highly cross-linked UHMWPE.

NOTES OF CAUTION (Cont.)

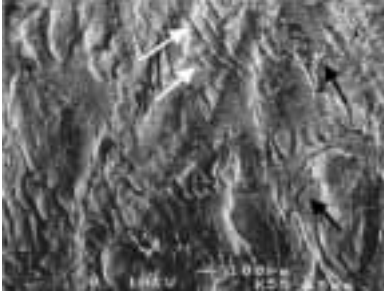

Figure 13: SEM of retrieved Durasul™ liner after 7 months in vivo demonstrating surface cracking (55x). From Bradford-Collons, et al., Soc Biomater, 2002.



Figure 14: SEM of retrieved Durasul™ liner after 18 months in vivo demonstrating cracking (55x). From Bradford-Collons, et al., in press.

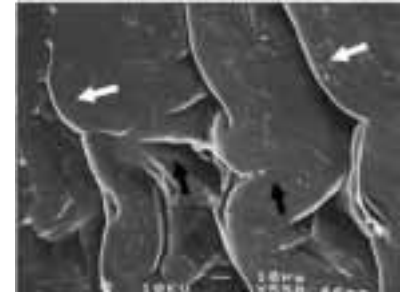

Figure 15: Magnification of surface damage in Figure 14 (550x). From Bradford-Collons, et al., in press.

*White arrows indicate machining marks with cracks running parallel.
Black arrows indicate cracks perpendicular to machining marks.*

The absence of information on the long-term clinical performance of highly cross-linked UHMWPE components prompted the Medical Devices Agency of the United Kingdom in June 1999 to issue a Safety Notice (MDA SN1999(23)) advising caution in their use and careful patient monitoring.

TAKE HOME MESSAGE

- For the past three decades UHMWPE hip and knee components have been predominantly sterilized by gamma irradiation in air and have shown remarkable overall resilience in terms of clinical function.
- Nevertheless, aseptic loosening attributed to polyethylene debris-induced osteolysis is of contemporary concern. As the indications for total joint replacement expand to younger patients and life expectancy increases, the interest in alternative bearing materials has accelerated.
- It is now known that irradiation in an environment in which oxygen is present encourages oxidation of UHMWPE components, resulting in embrittlement and a decrease in wear performance. This process continues when components are shelf-stored in air or in permeable packaging for prolonged periods before use.
- Sterilization in oxygen-free environments with barrier packaging and shelf-dating reduce the risk of material compromise.
- The use of ethylene oxide or gas plasma as an alternative sterilization method avoids oxidative degradation, but does not realize potential benefits with respect to reduction of abrasive wear derived from cross-linking.
- Recently a number of “improved” polymers have emerged whose common benefit resides in increased cross-linking concurrent with minimization of oxidation. Pin-on-disk testing has not been shown to predict *in vivo* performance, but hip simulator models suggest a significant reduction in wear with these new polymers. However, early clinical retrieved components demonstrate wear behavior not predicted by simulator studies.
- These processes, however, change the chemical structure of the polymer affecting both static mechanical properties and fatigue characteristics.
- A number of these polyethylenes have received clearance by the FDA despite the absence of clinical reports.
- Corporate responsibility to assess clinical performance via evidence-based studies is needed and should be a consideration in the surgeon’s selection of highly cross-linked polymer components.